

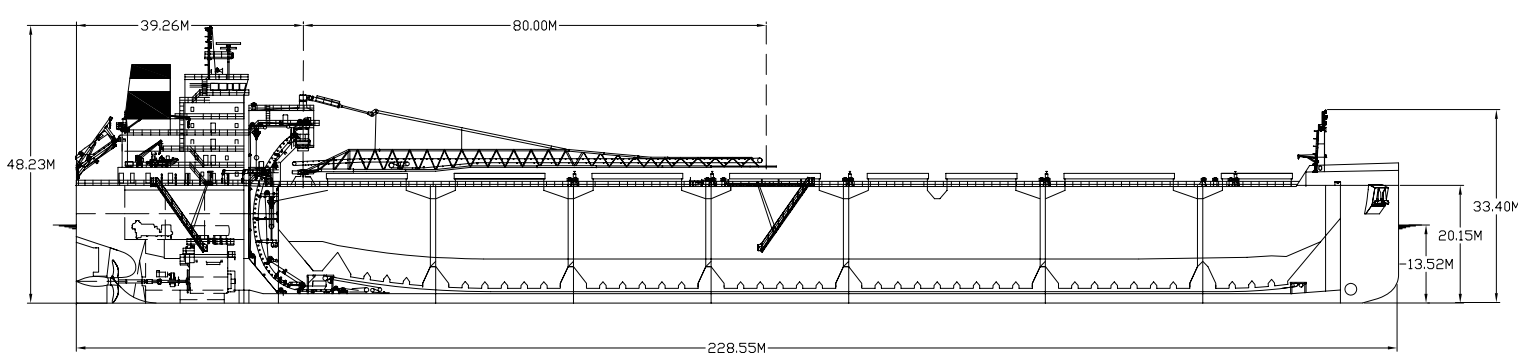

Built	2013
Classification	Lloyd's Register
Length Overall	228.55 metres
Length between Perps	225.19 metres
Breadth Moulded	32.26 metres
Depth Moulded	20.16 metres
Total Hold Capacity (inc. hatches)	71,476.0 cubic metres
Draught Summer	13.517 metres
Deadweight	71,405.30 tonnes
Gross Tonnage	43,691.00 tonnes
Net Tonnage	17,087.00 tonnes
Bow Thruster	1,500.00 kW
Length of Boom	80.00 metres
Discharge Rate	Coal 4,200 tonnes/hr
	Gypsum 4,500 tonnes/hr
	Aggregates 5,000 tonnes/hr
	Iron Ore 6,000 tonnes/hr

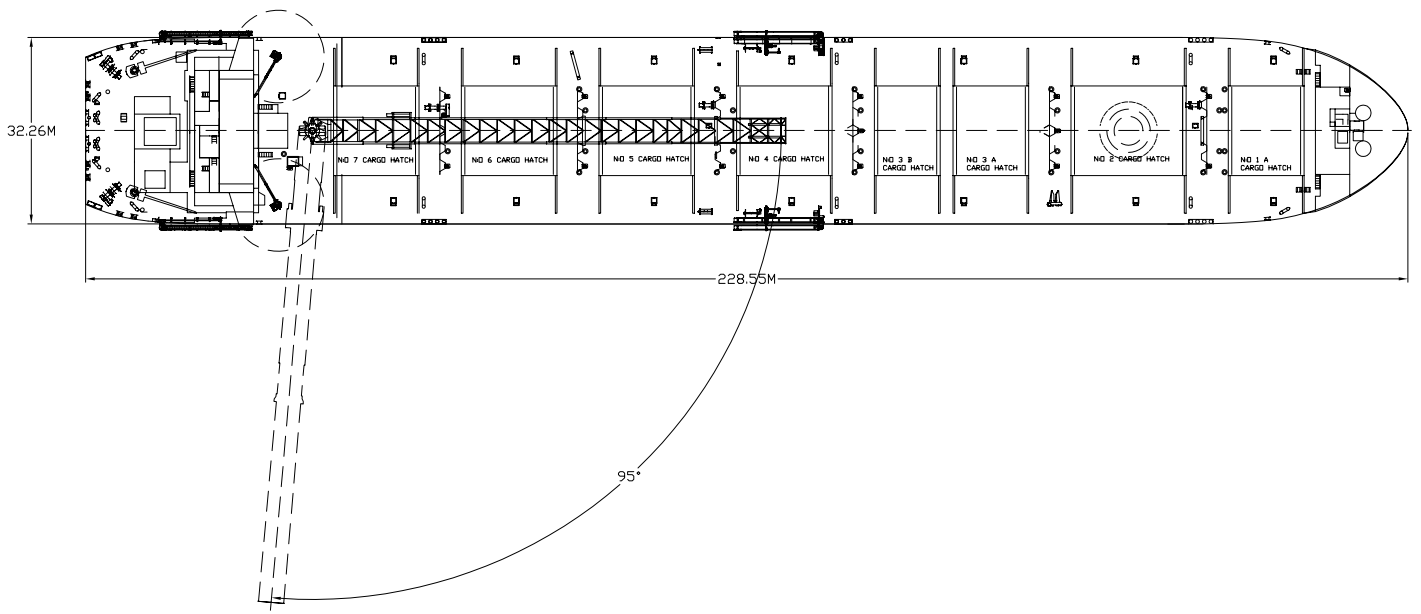
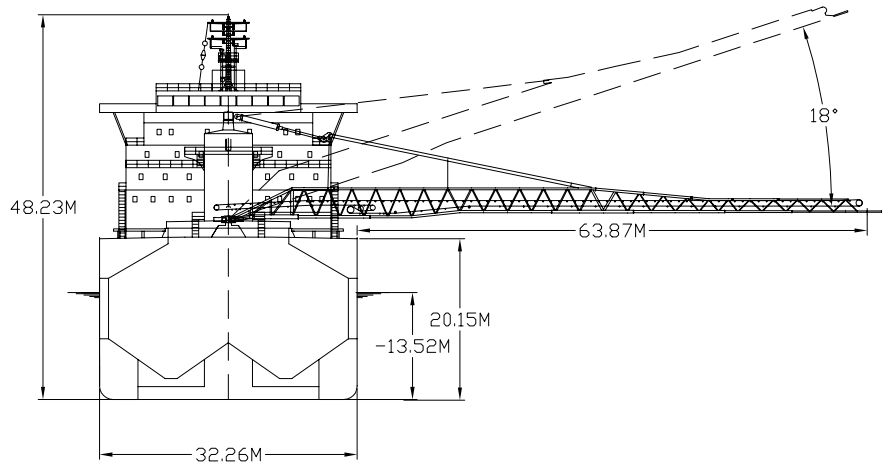

Air Drafts													
(metres)													
Draft Condition	Trim (at PP)	Draught		Stem	Foremast	Hatches (rolled to one side)			Cargo Gear	Main Mast	Funnel	Stern	Maximum
		AP	FP			Forward	Midship	Aft					
Height above keel				24.25	33.40	21.26	21.26	21.26	36.06	48.23	44.14	20.35	48.23
Light Ship	4.38	5.07	0.69	23.58	30.54	20.26	18.47	16.83	31.72	43.57	39.25	15.23	43.57
Normal Ballast 50% Bunker	2.89	8.22	5.33	18.95	26.65	15.72	14.55	13.46	28.34	40.30	36.05	12.11	40.30
Fully Loaded 50% Bunker	0.67	13.85	13.17	11.10	19.91	8.04	7.76	7.51	22.35	34.47	30.35	6.52	34.47

Hatch and Hold Specifications										
Hold Number	1	2	3	4	5	6	7	TOTAL		
Hold Volumes (cubic metres)										
Maximum Cubic	7,390.0	11,270.0	14,175.0	9,866.0	9,865.0	9,870.0	9,040.0	71,476.0		
Hold Openings (metres)										
Hatch Number	1	2	3A	3B	4	5	6	7		
Opening Length	12.00	18.90	12.00	10.30	15.30	15.30	15.30	13.80		
Opening Width	15.10	15.10	15.10	15.10	15.10	15.10	15.10	15.10		
Coaming Height above Keel	21.26	21.26	21.26	21.26	21.26	21.26	21.26	21.26		
Hatch Information (metres)										
Description	side-rolling panels	side-rolling panels	side-rolling panels	side-rolling panels	side-rolling panels	side-rolling panels	side-rolling panels	side-rolling panels	side-rolling panels	
Operation	hydraulic	hydraulic	hydraulic	hydraulic	hydraulic	hydraulic	hydraulic	hydraulic	hydraulic	
Hatch Length	12.30	19.11	12.30	10.61	15.71	15.71	15.71	14.01		
Hatch Width	16.84	16.84	16.84	16.84	16.84	16.84	16.84	16.84		
Hatch Top Height above Keel	22.04	22.04	22.04	22.04	22.04	22.04	22.04	22.04		

Cargo Handling Equipment	
• Two 0.66 - 2.54 m/s hold conveyors	
• Two 2.5 m/s transfer conveyors	
• One 1.3 - 4.3 m/s Boom conveyor	
• One 1.4 - 4.8 m/s 'C' Loop conveyor	
• Tunnel Belts - Wide:	2134 mm
• Boom Belt - Wide:	1981 mm
• Transfer Belt - Wide:	1981 mm
• All Belts have 35 degree trough	
• Dust Suppression: dust collectors plus water sprayers on the boom and foam sprayers in the transfers.	
• Discharge Rate:	
Aggregates	5,000 tonnes/hr
Coal	4,200 tonnes/hr
Iron Ore	6,000 tonnes/hr
• Maximum boom outreach: 63.87 metres	

Speed Consumption					
	Speed		Consumption		
	Loaded	Ballast	Loaded	Ballast	Port
At Sea	13.00	13.50	27.00	25.00	N/A
Loading					2.50
Discharge					6.00

For more information on this ship please visit
www.cslships.com

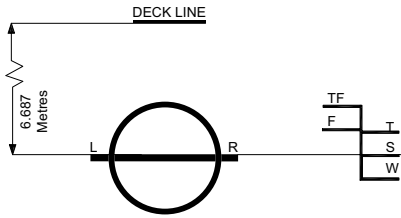

ASSIGNED DRAFTS			
Season	Draft (metre)	Displ. (tonnes)	DWT (tonnes)
TF	14.11	89,423	73,355
F	13.83	87,477	71,409
T	13.80	89,465	73,397
S	13.52	87,473	71,405
W	13.24	85,485	69,417

Light Ship
16,068 tonnes

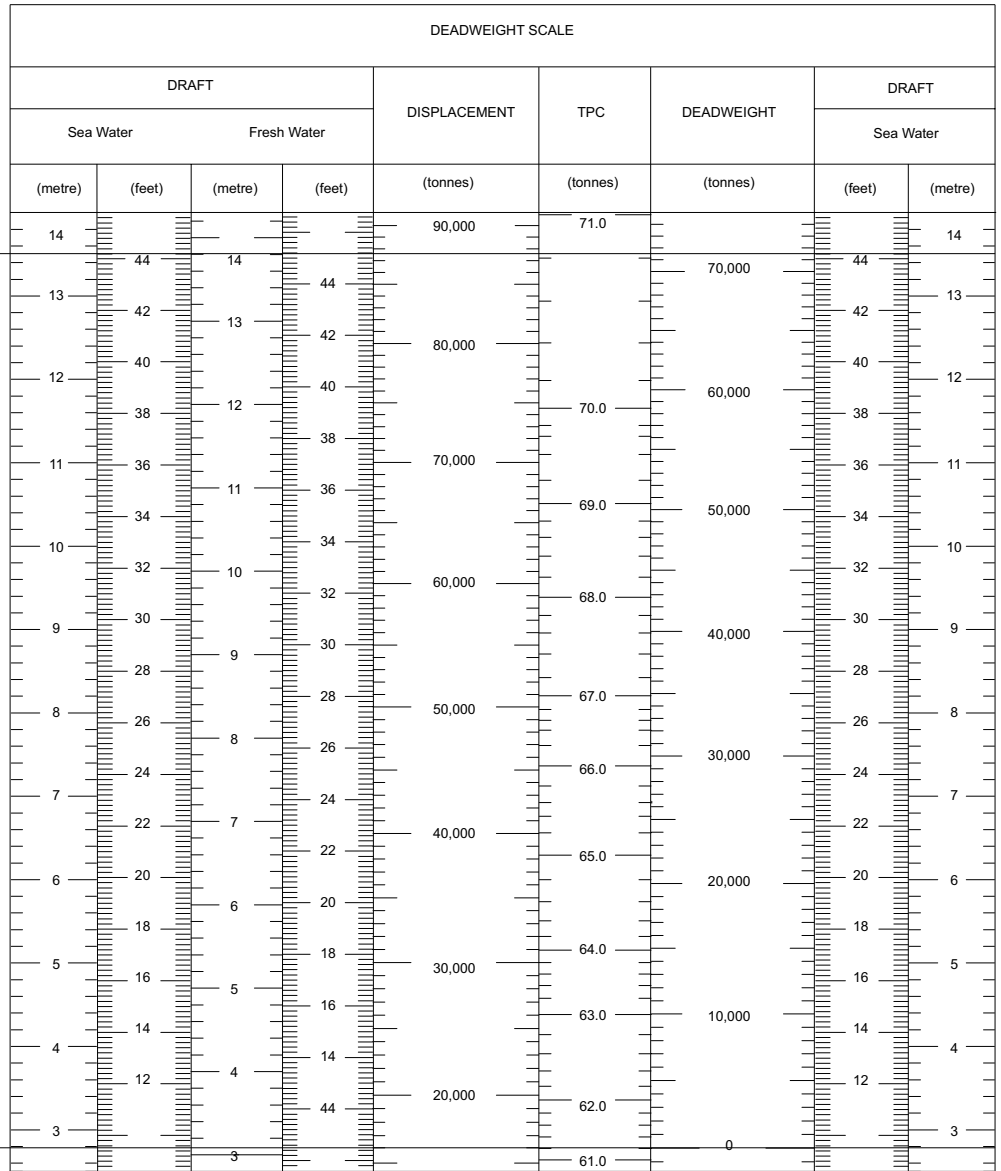

For more information on this ship please visit www.cslships.com